

# Rooted Routing in the Plane

Bruce Reed

*Equipe Combinatoire CNRS*

*Université Pierre et Marie Curie*

*Case 189, 4 Place Jussieu*

*75252 Paris Cedex 05*

*France*

email: breed@muff.cs.mcgill.ca

We describe an algorithm due to Reed, Robertson, Schrijver and Seymour, that finds vertex disjoint paths in a planar graph given the endpoints. When the number of required paths is fixed the algorithm runs in linear time. It can be extended — with the same time complexity — to graphs embeddable in any fixed surface.

## 1. THE PROBLEM

A *graph*  $G$  consists of a set  $V(G)$  of *vertices* and a set  $E(G)$  of *edges* each of which is an ordered pair of vertices. These objects, despite their simple structure, can be used to model important properties of a wide variety of mathematical and physical systems. One of their most important applications is to the study of routing in networks. Here, the vertices represent sites (cities, computers, airports) and the edges represent connections (roads, telephones, flights).

A fundamental result in routing theory concerns disjoint paths between two specified sets of vertices in a graph  $G$ . (A *path* is a sequence of distinct vertices between each consecutive pair of which there is an edge. The *endpoints* of a path are the first and last elements of the sequence. The vertices of a path of length at least three form a *simple cycle* if there is an edge between the path's endpoints.)

MENGER'S THEOREM (see [1]). *If  $S$  and  $T$  are disjoint sets of vertices of a graph  $G$  then exactly one of the following holds:*

- (i) *There are  $k$  vertex disjoint paths each with one endpoint in  $S$  and the other in  $T$ ,*
- (ii) *There is a set  $X$  of at most  $k - 1$  vertices in  $G$  such that there is no path in  $G - X$  with one endpoint in  $S$  and the other in  $T$ .*

Note that it is obvious that at most one of (i) or (ii) can hold.

Practical polynomial time algorithms exist to find a maximum cardinality set of vertex disjoint paths between two sets  $S$  and  $T$  of vertices in a graph. These algorithms can be generalized to solve problems in commodity routing as well as in scheduling and resource allocation. Indeed, practical problems of this type with tens of thousands of nodes are routinely solved.

In many applications, we actually want to find paths for which the endpoints have been specified in advance (wire routing in VLSI design is one example; another is commodity routing with more than one commodity, we do not want to send apples to someone who wants oranges). Routing problems of this type are much harder to solve. In fact, the following problem is NP-complete [2], even on the plane [3].

**RVDP** (Rooted Vertex Disjoint Paths)

**Input:** A graph  $G$ , an integer  $l$  and two sets of vertices  $S = \{s_1, \dots, s_l\}$  and  $T = \{t_1, \dots, t_l\}$ .

**Question:** Are there  $l$  vertex disjoint paths  $P_1, \dots, P_l$  such that  $P_i$  has endpoints  $s_i$  and  $t_i$ ?

In a groundbreaking series of papers, Robertson and Seymour recently proved (amongst a host of other seminal results) that for any  $l$  there is a polynomial time algorithm to solve those instances of RDVP in which we are trying to find at most  $l$  paths. (Previously, this could only be done for  $l = 2$ , see [10,11,13]). Actually, Robertson and Seymour's algorithm solves the more general problem, given below.

A graph is *connected* if there is a path between any two of its vertices. A *tree* is a graph which is connected but such that removing any edge destroys the connectivity. Alternatively, a graph is a tree if it is connected and contains no cycle. A partition  $\Delta = \{\Delta_1, \dots, \Delta_p\}$  of a set  $X$  of vertices of  $G$  is realizable if there are vertex disjoint trees  $T_1, \dots, T_p$  in  $G$  such that  $\Delta_i \subseteq T_i$ . A *realization* of  $\Delta$  is such a set of trees.

**realizations**

**Input:** A graph  $G$  and a set  $X$  with  $|X| = k$ .

**Question:** which partitions of  $X$  are realizable in  $G$ ?

Now, in an instance of RVDP ( $G, S, T$ ) we are simply asking if the partition  $\{\{s_1, t_1\}, \dots, \{s_l, t_l\}\}$  of  $S \cup T$  is realizable in  $G$ . Thus we can apply an algorithm for  $2l$ -realizations directly to solve instances of RVDP in which we are trying to find  $l$  paths.

Robertson and Seymour's algorithm for  $k$ -realizations is described and analyzed in [9] using results from [6,7,8]. It runs in  $O(n^3)$  times and actually finds all the realizations which exist. Reed (unpublished) has developed a modified version of the algorithm which runs in  $O(n^2)$  time.

In this paper, we discuss a linear-time algorithm for instances of  $k$ -realizations in which  $G$  is a *planar* graph (a graph is planar if it can be drawn in the plane so that its edges do not cross). This algorithm is due to REED, ROBERTSON, SCHRIJVER, and SEYMOUR [4] (see also [5]). We will also discuss how to generalize this algorithm to more complicated surfaces and make some remarks about Robertson and Seymour’s algorithm for  $k$ -realizations in arbitrary graphs.

## 2. THE ALGORITHM

Part of our work has already been done for us. In [7], ROBERTSON and SEYMOUR discuss a procedure which yields a linear-time algorithm for solving instances of  $k$ -realizations for graphs drawn in a disk so that all the vertices of  $X$  are on the boundary of the disc. Furthermore, SUZUKI ET AL. [12] have developed a linear-time algorithm for solving instances of  $k$ -realizations for which  $G$  is a graph embedded in a cylinder (i.e. a disk from whose interior an open disc has been removed) so that the vertices of  $X$  lie on the boundary of the cylinder. We will use these algorithms as the basis of our algorithm. In fact we will obtain for each  $c$  and  $k$  an algorithm which solves instances of  $k$ -realizations for which  $G$  is a graph embedded on a surface  $\Sigma$  obtained by removing from the plane  $c$  open discs whose closures are disjoint. We call such a surface a *punctured plane*. The boundary of  $\Sigma$  is denoted  $bd(\Sigma)$ . Each component of the boundary of a punctured plane is a *cuff*. We will give a linear-time algorithm to solve the following problem for any fixed  $c$  and  $k$ .

### **$c$ -embedded $k$ -realizations**

**Input:** A graph  $G$  embedded on a punctured plane  $\Sigma$  and a subset  $X$  of the vertices of  $G$  on  $bd(\Sigma)$  with  $|X| = k$ .

**Question:** which partitions of  $X$  are realizable in  $G$ ?

We remark that any instance of  $k$ -realizations  $(G, X)$  for which  $G$  is planar is also an instance of  $k$ -embedded  $k$ -realizations as we can draw  $k$  disjoint discs each intersecting  $G$  at one of the vertices of  $X$ . Thus, we obtain our desired algorithm for  $k$ -realizations on planar graphs.

As we have already remarked, there are algorithms for solving  $c$ -embedded  $k$ -realizations in linear time if  $c$  is 1 or 2. We describe a recursive algorithm for solving such problems for  $c$  at least three. Our algorithm is based on two reduction procedures.

### *Schisms — cutting the surface*

We begin with an example of the first procedure. Consider the situation depicted in Figure 1(a). We have a graph  $G$  embedded on a punctured plane  $\Sigma$ ,  $X$  (indicated by black squares) on  $bd(\Sigma)$ , as well as a simple closed curve  $J$  in  $\Sigma$  intersecting  $G$  in one vertex  $v$ . Cutting along  $J$  yields two new punctured planes  $\Sigma_1$  and  $\Sigma_2$  each with three cuffs (to be precise, each of these surfaces is the closure of some component of  $\Sigma - J$  and hence their intersection is  $J$ ). As shown in Figure 1(b,c), we also obtain two subgraphs  $G_1 := \Sigma_1 \cap G$  and  $G_2 := \Sigma_2 \cap G$ .

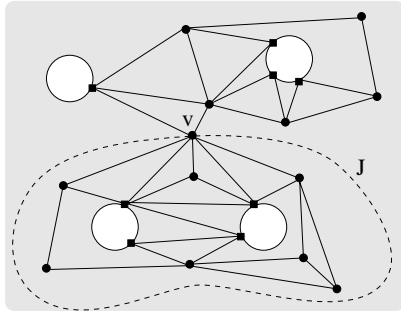

(a)

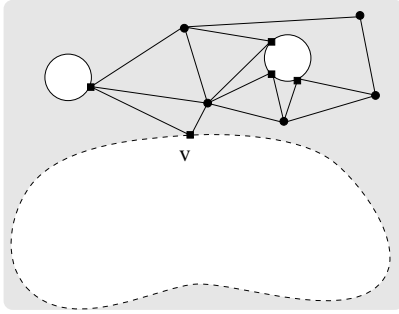

(b)

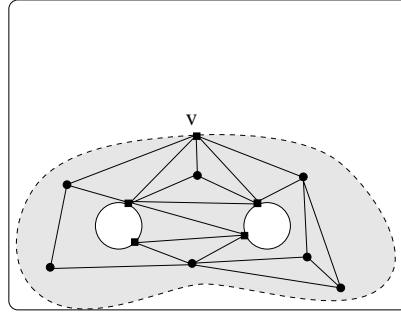

(c)

FIGURE 1. A cut reduction

As we are about to see, cutting along  $J$  splits this problem into two simpler problems. To begin, consider any partition  $\Delta = \{\Delta_1, \dots, \Delta_p\}$  of  $X$ . If  $\Delta$  is realizable in  $G$  then let  $T_1, \dots, T_p$  be a realization of  $\Delta$  in  $G$ . Obviously, either  $v$  is in  $T_i$  for some  $i$  between 1 and  $p$ , or we have that  $T_1, \dots, T_p, v$  is a realization of  $\Delta^0 = \{\Delta_1, \dots, \Delta_p, \{v\}\}$  in  $G$ . Thus, if we set  $\Delta^i = \{\Delta_1, \dots, \Delta_{i-1}, \Delta_i + v, \Delta_{i+1}, \dots, \Delta_p\}$ , then  $\Delta$  is realizable in  $G$  if and only if one of  $\Delta^0, \dots, \Delta^p$  is realizable in  $G$ . Now, for each  $i$  between 0 and  $p$ , set  $\Delta^{i,1} = \{\Delta_1^i \cap G_1, \dots, \Delta_p^i \cap G_1\}$ , set  $\Delta^{i,2} = \{\Delta_1^i \cap G_2, \dots, \Delta_p^i \cap G_2\}$ , and note that  $\Delta^i$  is realizable in  $G$  if and only if  $\Delta^{i,1}$  is realizable in  $G_1$  and  $\Delta^{i,2}$  is realizable in  $G_2$ . Thus, setting  $X_1 = (X + v) \cap G_1$  and  $X_2 = (X + v) \cap G_2$ , we see that we can solve our instance  $(G, X, \Sigma)$  of 4-embedded 8-realizations by solving the two instances  $(G_1, X_1, \Sigma_1)$  and  $(G_2, X_2, \Sigma_2)$  of 3-embedded 5-realizations.

More generally, assume we are given an instance  $(G, X, \Sigma)$  of  $c$ -embedded  $k$ -realizations and a simple closed curve  $J$  such that  $J$  intersects  $G$  only at vertices,  $|J \cap V(G)| = l$ , and each component of  $\Sigma - J$  contains at least two cuffs of  $\Sigma$ . Then, for some  $c_1, c_2, k_1, k_2$  with  $c_1, c_2 < c$  and  $k_1, k_2 < k + l$  we

can combine the solution of an instance of  $c_1$ -embedded  $k_1$ -realizations with the solution of an instance of  $c_2$ -embedded  $k_2$ -realizations to obtain a solution to our original problem. Figure 2 shows six different types of cuts which will permit reductions of the same kind. In each case, we obtain 1, 2, or 3 new

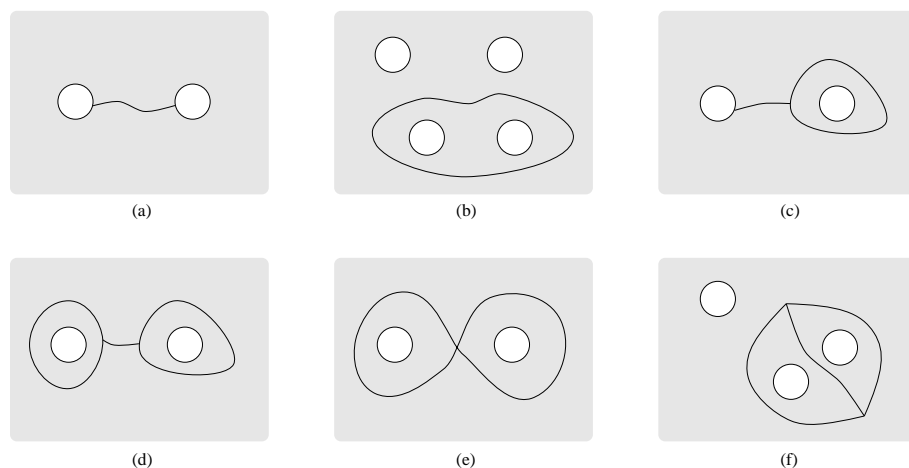

FIGURE 2. *The schisms*

problems each of which is an instance of  $c'$ -embedded  $k'$ -realizations for some integers  $c'$  and  $k'$  with  $c' < c$ . For each pair  $(c, k)$  we will permit reductions using cuts of these five types whose intersection with  $V(G)$  is bounded by some function  $h(c, k)$  defined below (we must bound this value to ensure that the new problems are manageable).

We now define precisely the cuts depicted in Figure 2. Let  $\Sigma$  be a punctured plane. An *O-arc* of  $\Sigma$  is a simple (i.e. non self-intersecting) closed curve of  $\Sigma - bd(\Sigma)$ . An *I-arc* is a simple arc with both endpoints on  $bd(\Sigma)$ , we also permit the degenerate case when the two endpoints coincide. An arc is *proper* if it intersects  $G$  only at vertices. The length of a proper arc is the number of times it intersects  $V(G)$ . We say that an O-arc  $J$  surrounds a cuff  $C$  if for some component  $U$  of  $\Sigma - J$  we have  $C = U \cap bd(\Sigma)$ . A *lollipop* consists of a proper O-arc  $J$  surrounding some cuff  $C$  and a proper simple arc from  $J$  to  $bd(\Sigma) - C$  whose interior is contained in  $\Sigma - bd(\Sigma) - J$  (see Figure 2(c)). A *bicycle* consists of two disjoint proper O-arcs  $J_1$  and  $J_2$  surrounding different cuffs and a proper simple arc between them whose interior is contained in  $\Sigma - bd(\Sigma) - J_1 - J_2$  (see Figure 2(d)). A *butterfly* consists of two proper O-arcs surrounding different cuffs which meet at a single point (see Figure 2(e)). A *three-path* consists of three proper simple arcs  $J_1, J_2, J_3$  in  $\Sigma - bd(\Sigma)$  with the same endpoints but internally disjoint such that the three components of  $\Sigma - J_1 - J_2 - J_3$  each contain exactly one cuff (and thus there are precisely three

cuffs; see Figure 2(f)). A *schism* is any of a lollipop, a bicycle, a butterfly, a three-path, a proper I-arc with its endpoints on different cuffs (see Figure 2(a)), or a proper O-arc  $J$  such that each component of  $\Sigma - J$  contains at least two cuffs (see Figure 2(b)). We always cut along schisms.

Upon an application of a cut reduction a problem splits into at most three new problems. So, an easy induction shows that if we repeatedly reduce the new problems obtained until we are left only with instances of  $c$ -embedded  $k$ -realizations where  $c$  is at most two, then we consider at most  $3^d$  subproblems whilst solving an instance of  $d$ -embedded  $k$ -realizations (a slightly more complicated induction shows that we consider at most  $4d+8$  subproblems). We can solve each of the 1 or 2 cuff problems which remain using the algorithm of Suzuki et al. mentioned earlier. Thus, if each reduction can be performed in linear time then the whole algorithm can be implemented in linear time. We avoid the details of the simple procedures for combining the solutions of the subproblems.

Unfortunately, some graphs may not permit cut reductions and for this reason we may find it necessary to apply a sequence of reductions of a second type, namely deletion of an ‘irrelevant’ vertex, to obtain a cut reduction. However, this is simply a complication in the cut finding procedure. The analysis of the algorithm still follows the lines given in the above paragraph.

#### *Deleting an irrelevant vertex*

A vertex  $v$  in  $G$  is *irrelevant* if  $X$  has the same realizable partitions in  $G - v$  as in  $G$ . It is plausible that if a vertex is ‘deep’ in a simple part of  $G$  which is disjoint from  $X$ , then it is irrelevant. To make this precise, call a vertex  $v$  of a graph  $G$  embedded in a surface  $\Sigma$   *$l$ -isolated* if there are vertex disjoint cycles  $C_1, \dots, C_l$  of  $G$  bounding discs  $D_1, \dots, D_l$  of  $\Sigma - bd(\Sigma)$  such that  $v \subset D_1 \subset D_2 \dots \subset D_l$  (see Figure 3). Our second reduction procedure is motivated by the following lemma which is proved in the next section.

LEMMA 1. *For every  $c$  and  $k$  there exists a  $g(c, k)$  such that each  $g(c, k)$ -isolated vertex is irrelevant for every instance  $(G, X, \Sigma)$  of  $c$ -embedded  $k$ -realizations.*

Deleting  $g(c, k)$ -isolated vertices is our second reduction. Actually, in each iteration of the algorithm we will apply a sequence of vertex deletions which will finally permit us to apply a cut reduction. That this is, in fact, possible is suggested by the following lemma.

LEMMA 2. *Let  $g$  be a function satisfying the conditions of Lemma 1. Let  $h(c, k) = 6g(c, k) + 6$ . Let  $(G, X, \Sigma)$  be an instance of  $c$ -embedded  $k$ -realizations. Then either there is a  $g(c, k)$ -isolated vertex  $v$  or there is a schism  $J$  in  $\Sigma$  with  $|J \cap V(G)| \leq h(c, k)$ .*

The proof of Lemma 2 contains most of the core ideas we use in developing a fast implementation of the isolated vertex deleting/cut finding procedure. After proving Lemma 2, we discuss this implementation briefly.

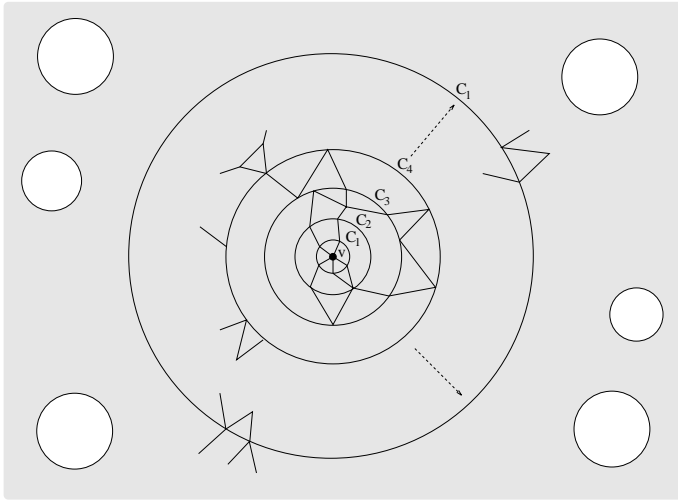

FIGURE 3. An  $l$ -isolated vertex

PROOF OF LEMMA 2. We begin with the following lemma.

LEMMA 3. If  $G$  is a graph embedded on a punctured plane, and  $v$  is a vertex of  $G$  then for any positive integer  $l$ , either

- (i)  $v$  is  $l$ -isolated,
- (ii) there is a proper simple arc  $J$  of  $\Sigma$  with one endpoint  $v$  and the other in  $bd(\Sigma)$  such that there are at most  $l - 1$  vertices on the interior of  $J$ ,
- (iii) there is a proper  $O$ -arc  $J_1$  of  $\Sigma$  and a proper simple arc  $J_2$  with one endpoint  $v$ , the other on  $J_1$ , and no internal points on  $J_1$  such that each component of  $\Sigma - J_1$  contains a cuff and  $|J_1 \cap V(G)| + 2|(J_2 - J_1) \cap V(G)| \leq 2l$ . (Note that we permit  $J_2$  to be a single point in which case  $J_1$  is simply an  $O$ -arc through  $v$ .)

PROOF. We shall prove this lemma by induction on  $l$ .

Consider a vertex  $v$  in a graph  $G$  embedded on a punctured plane. Let  $f$  be the face of the drawing of  $G - v$  which contains  $v$  (a *face* of the drawing is a connected component of the surface obtained by removing the edges and vertices). Let  $f, U_1, \dots, U_m$  be the components of  $\Sigma - bd(f)$  (see Figure 4). Note that each  $U_i$  is bounded by a simple cycle of  $bd(f)$  and that for any two distinct  $U_i$  and  $U_j$ , there is a proper  $O$ -arc  $J$  intersecting  $G$  at  $v$  and possibly in one vertex of  $bd(f)$  such that  $U_i$  and  $U_j$  are in different components of  $\Sigma - J$ .

Now, if  $f + bd(f)$  intersects  $bd(\Sigma)$  then there is an  $O$ -arc  $J$  with one end  $v$  and the other in  $bd(\Sigma)$  and all of its interior vertices in  $f$ . Otherwise, if there are

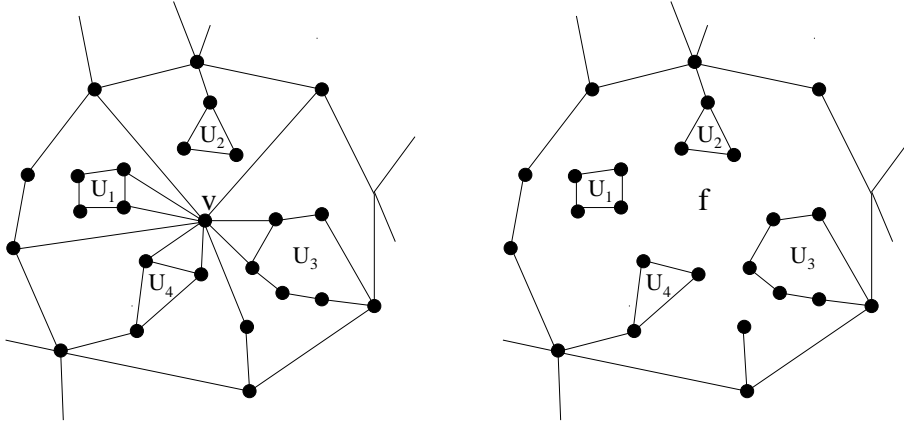

FIGURE 4.

at least two distinct components  $U_i$  and  $U_j$  of  $\Sigma - bd(f)$  containing cuffs then as noted above we can find a proper O-arc  $J$  of length at most 2 containing  $v$  such that each component of  $\Sigma - J$  contains a cuff. Finally, if there is a  $U_i$  such that all of the cuffs of  $\Sigma$  are in  $U_i$  then we let  $C$  be the simple cycle in  $bd(f)$  bounding  $U_i$ . We note that the existence of  $C$  implies that  $v$  is 1-isolated. Since, one of these three possibilities must occur, we see that Lemma 3 is true for  $l = 1$ .

So, we assume that  $l \geq 2$  and the lemma holds for all  $l' \leq l$ . As discussed above, either there is an arc as in (ii), an O-arc as in (iii), or a component  $U$  of  $\Sigma - f - bd(f)$  bounded by a simple cycle  $C$  of  $bd(f)$  such that  $U$  contains all the cuffs of  $\Sigma$ . In this case, let  $G^*$  be the graph obtained from  $G \cap U$  by adding a vertex  $v^*$  adjacent to precisely those vertices of  $G \cap U$  which in  $G$  are adjacent to some vertex of  $C$ . It is clear that the given embedding of  $G \cap U$  can be extended to an embedding of  $G^*$  in such a way that  $v^*$  coincides with  $v$  (see Figure 5). We now apply our inductive hypothesis and obtain that either  $v^*$  is  $l - 1$ -isolated in  $G^*$ , there is a simple arc  $J$  proper with respect to  $G^*$  from  $v^*$  to  $bd(\Sigma)$  whose interior contains at most  $l - 2$  vertices, or there is an O-arc  $J_1$  proper with respect to  $G^*$  and a simple arc  $J_2$  proper with respect to  $G^*$  which links  $v^*$  to  $J_1$  such that there is a cuff in each component of  $\Sigma - J_1$  and  $|J_1 \cap V(G)| + 2|(J_2 - J_1) \cap V(G)| \leq 2l$ . If  $v^*$  is  $(l - 1)$ -isolated in  $G^*$  then  $v$  is  $l$ -isolated in  $G^*$  because  $C$  can be added to the set of cycles isolating  $v^*$  to obtain a larger set isolating  $v$ . On the other hand, if either an arc  $J$  or arcs  $J_1$  and  $J_2$  as described above exist then these can be modified to show that one of (ii) or (iii) holds. Thus the lemma holds for  $l$ , as desired.  $\square$

**COROLLARY 4.** *For any  $l$ , if  $G$  is a graph embedded on a punctured plane then either  $G$  contains an  $l$ -isolated vertex,  $G$  contains a proper I-arc with its*



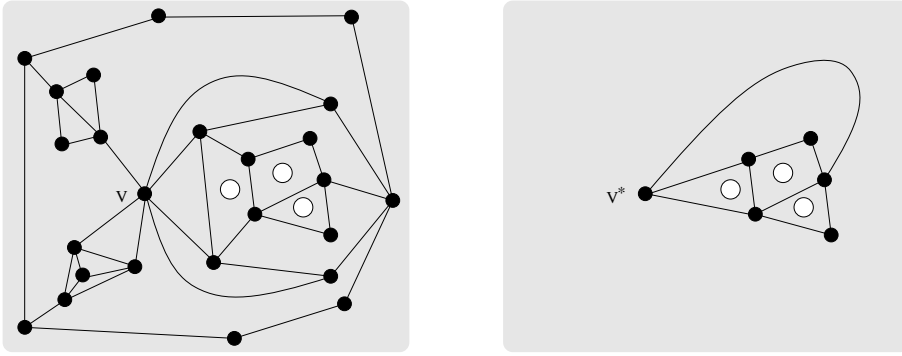

FIGURE 5.

*endpoints on different cuffs containing at most  $2l + 2$  vertices, or  $G$  contains an O-arc  $F$  containing at most  $2l$  vertices such that each component of  $G - F$  contains a cuff.*

PROOF. Let  $J$  be a proper I-arc  $J$  of  $G$  with its endpoints on different cuffs and subject to this intersecting  $G$  as little as possible. Let  $v$  be a vertex of  $J$  such that one component of  $J - v$  contains  $\lfloor \frac{|J \cap V(G)| - 1}{2} \rfloor$  vertices and the other contains  $\lceil \frac{|J \cap V(G)| - 1}{2} \rceil$ . Now apply Lemma 3 to  $v$ . We see that either  $v$  is  $l$ -isolated, or there is an O-arc  $J_1$  of length at most  $2l$  such that each component of  $\Sigma - J_1$  contains a cuff, or there is an I-arc from  $v$  to some cuff containing at most  $l + 1$  vertices. The minimality of  $J$  implies that in this last case,  $J$  contains at most  $2l + 2$  vertices. The corollary follows.  $\square$

Now, consider a graph  $G$  embedded in a punctured plane with cuffs  $C_1, \dots, C_c$ . For each  $i$ , if there is a proper O-arc surrounding  $C_i$  which contains at most  $2g(c, k)$  vertices then let  $C'_i$  be such an O-arc which cuts off as much of  $\Sigma$  as possible, in the sense that there is no proper O-arc  $C^*_i$  containing at most  $2g(c, k)$  vertices and surrounding  $C_i$  such that  $C_i$  and  $C'_i - C^*_i$  are in the same component of  $\Sigma - C^*_i$ . If there is no such proper O-arc then we set  $C'_i = C_i$ .

If for some distinct  $i$  and  $j$ ,  $C'_i$  and  $C'_j$  intersect then there is a schism (either a butterfly, three-path, or an O-arc  $J$  such that each component of  $\Sigma - J$  contains at least two cuffs) which is contained in their union and hence contains at most  $4g(c, k)$  vertices of  $G$ .

Otherwise, let  $\Sigma'$  be the surface obtained from  $\Sigma$  by deleting for each  $i$  such that  $C'_i$  is an O-arc, the component of  $\Sigma - C'_i$  containing  $C_i$ . Let  $G' = G \cap \Sigma'$ . Then  $G'$  is a graph embedded in a punctured plane with  $c$  cuffs. (See Figure 6). So, by Corollary 4 applied to  $G'$ , either there is a  $g(c, k)$ -isolated vertex  $v$  in  $G$  or there is a proper O-arc  $J$  of  $\Sigma'$  of length at most  $2g(c, k)$  such that each component of  $\Sigma' - J$  contains a cuff, or there is a proper I-arc with its endpoints

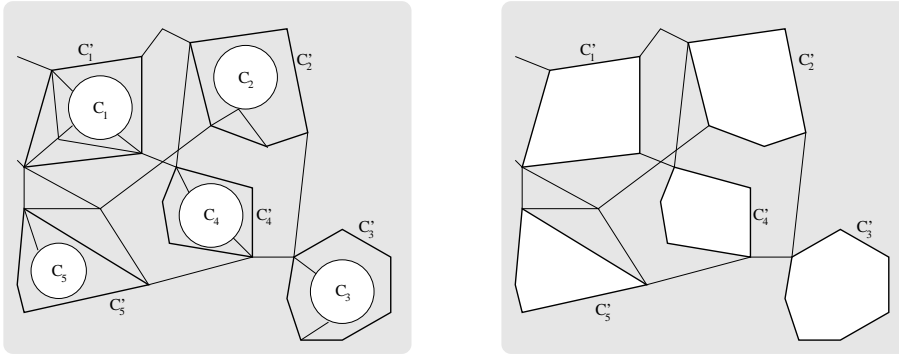

FIGURE 6.

on different cuffs of  $\Sigma'$  of length at most  $2g(c, k) + 2$ .

Now, we note that any  $g(c, k)$ -isolated vertex of  $G'$  is also a  $g(c, k)$ -isolated vertex of  $G$ . Furthermore, any proper I-arc in  $\Sigma'$  of length at most  $2g(c, k) + 2$  corresponds to an I-arc, lollipop, or bicycle of  $\Sigma$  of length at most  $6g(c, k) + 2$ . Finally, if  $J$  is an O-arc in  $\Sigma'$  of length at most  $2g(c, k)$  such that both components of  $\Sigma' - J$  contain a cuff then by our choice of the  $C'_i$  both these components must contain two cuffs.

Thus, we see that our application of Corollary 4 to  $G'$  yields either a  $g(c, k)$ -isolated vertex of  $G$  or a schism in  $G$  of length at most  $6g(c, k) + 2$ .  $\square$

Our Proof of Lemma 2 is algorithmic. We now discuss how to convert the proof into a linear time algorithm for finding a cut reduction. To begin we remark that the proof of Lemma 3 and Corollary 4 can be converted into an algorithm which returns a vertex  $v$ , an integer  $l$ , as well as both  $l$  nested circuits  $C_1, \dots, C_l$  surrounding  $v$  each of which bounds a disc disjoint from  $bd(\Sigma)$  and either a proper I-arc of length at most  $2l + 3$  whose endpoints are on different cuffs or a proper O-arc  $J_1$  and a proper simple arc  $J_2$  from  $v$  to  $J_1$  such that  $|J_1 \cap V(G)| + 2|(J_2 - J_1) \cap V(G)| \leq 2l + 2$  and each component of  $\Sigma - J_1$  contains a cuff.

Suppose first that we return an O-arc  $J_1$  and an arc  $J_2$  from  $v$  to  $J_1$  such that each component of  $\Sigma - J_1$  contains at least two cuffs. If  $l$  is less than  $g(c, k) + 1$  then  $J_1$  is a schism of length at most  $2g(c, k) + 4$  which is less than  $h(c, k)$  and we can cut along it. If  $l$  is greater than  $g(c, k)$  then, as shown in Figure 7, we first delete all the vertices of  $G$  contained inside the disk bounded by  $C_{l-g(c, k)}$  to obtain a new embedded graph  $G'$ . Repeated applications of Lemma 1 ensure that a partition of  $X$  is realizable in  $G$  if and only if it is realizable in  $G'$ . Note also that  $J_1$  is now a schism intersecting  $G'$  in at most  $2g(c, k) + 1$  vertices so we can cut along it to reduce the problem.

Similarly, if we return with an I-arc whose endpoints are on different cuffs

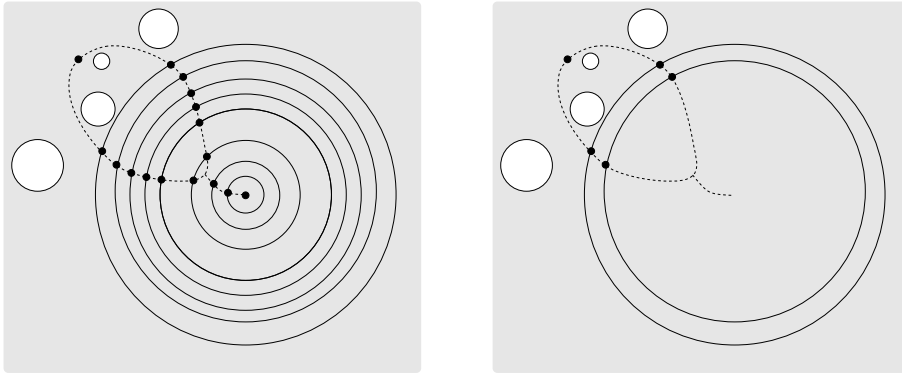

FIGURE 7.

then we can find a new graph  $G'$  and a corresponding I-arc which intersects  $G'$  in at most  $2g(c, k) + 3$  vertices such that cutting along this I-arc yields a new problem in a punctured plane with one fewer cuffs.

Finally, if we return with an O-arc  $J_1$  surrounding some cuff  $K$  and a proper simple arc  $J_1$  from  $v$  to  $J_2$  then we will iterate the cut finding process described above. In each iteration, we delete permanently part of our graph and also temporarily delete a part of our graph which we will replace at the end of the cut finding procedure. The part temporarily deleted is contained inside an O-arc surrounding a cuff and in fact this O-arc will take the place of the cuff as we also temporarily delete part of the surface. Now, in the final iteration of the cut finding algorithm, if we find a schism which is an O-arc this will still be a schism of the same length in the graph obtained by replacing all the momentarily deleted parts. However, if we terminate by finding an I-arc then this I-arc need not be an I-arc in the original surface. It will however correspond to a short lollipop, bicycle, or I-arc along which we can cut.

Forthwith the details. First, in a non-final iteration, we can permanently delete vertices as in the final iteration to obtain a new graph  $G'$  such that  $J_1$  has length at most  $2g(c, k) + 1$  with respect to  $G'$  and still surrounds  $K$ . Now, we will repeat the cut finding process just described on the graph  $G^*$  obtained from  $G'$  by temporarily deleting the component of  $\Sigma - J_1$  containing  $K$  (thus  $G^*$  is embedded on a new punctured plane one of whose cuffs is  $J_1$ ). Of course, we may repeat this process many times but eventually we must terminate in one of the two ways described above as it is clear that the length of the shortest of all the I-arcs between two cuffs halves at each step. Further, since each "pseudo-cuff" is actually an O-arc with length at most  $2g(c, k) + 1$ , it is clear that we can reduce along a schism of length at most  $h(c, k)$  in the graph obtained by replacing the temporarily deleted parts of the graph.

This completes the description of the cut finding algorithm we avoid dis-

cutting the straightforward details of the linear time implementation. We remark only that the time taken in a non-final iteration is actually proportional to the sum of the sizes of the subgraphs deleted temporarily and permanently.

We close by remarking that we actually only ever cut along I-arcs, O-arcs, bicycles, and lollipops. The other schisms were added for ease of exposition.

### 3. OTHER SURFACES

Essentially the same algorithm can be applied in any surface (see [4] for details; see [14] for an introduction to graphs on surfaces). However there are two other kinds of schisms along which we may need to cut. Examples of these are depicted in Figure 8. Figure 8 shows a two simple closed curves  $J_1$  and  $J_2$  in

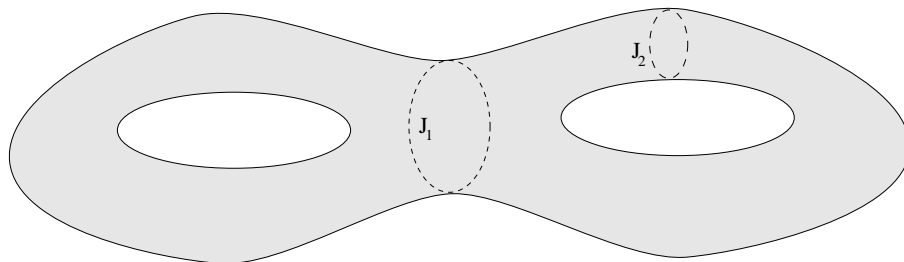

FIGURE 8.

a double torus. Cutting along  $J_1$  yields two surfaces each of which is obtained from the torus by deleting an open disc. Cutting along  $J_2$  yields one surface which is obtained from the torus by deleting two open disks. In general, we can cut along an O-arc  $J$  to simplify our problem as long as  $J$  does not bound a disc of the surface and does not surround a cuff (i.e. there is no cuff  $K$  such that  $J$  and  $K$  together bound a cylinder of the surface). Although such cuts may not decrease the number of cuffs, they always create ‘simpler’ surfaces.

We note that there is a technical detail we have not mentioned. How do we find the cut if there is only one cuff? This is very easy, but we omit the details.

### 4. A CRUCIAL LEMMA

The key to our algorithm is Lemma 1. It is a consequence of the following theorem of Robertson and Seymour first proved in [8].

**THEOREM 5.** *For every pair  $c$  and  $k$ , there is an  $f(c, k)$  such that for any instance  $(G, X, \Sigma)$  of  $c$ -embedded  $k$ -realizations, if the following three conditions hold then a partition  $\{\Delta_1, \dots, \Delta_p\}$  of  $\Delta$  of  $X$  is realizable in  $G$  if and only if it is realizable in  $\Sigma$ .*

- (i) No schism of  $\Sigma$  has length less than  $f(c, k)$ .

- (ii) *There is no O-arc  $J$  of  $\Sigma$  surrounding a cuff  $K$  such that  $|J \cap V(G)| < |K \cap X|$ .*
- (iii) *If  $J$  is an I-arc with both of its endpoints on the same cuff then either  $J$  has length at least  $f(c, k)$  or for some component  $U$  of  $\Sigma - J$ ,  $J + U$  is a disk and  $|(U - J) \cap X| \leq |(J - bd(\Sigma)) \cap V(G)|$ .*

Although Robertson and Seymour derive a strengthening of Lemma 1 from Theorem 5 (only partially published), we include a derivation of Lemma 1 assuming Theorem 5 here. This is because we require about of the 600 pages used by Robertson and Seymour.

PROOF OF LEMMA 1. We only prove the lemma for  $c \geq 3$ , the base case  $c = 1$  follows in a straightforward manner from results of [7], whilst the case  $c = 2$  can be proved in a manner similar to that we use for larger values of  $c$ .

We choose a function  $f$  satisfying Theorem 5 and then define a function  $g$  recursively by first setting:

$$h(c, k) = \max\{\max\{g(c', k') \mid c' < c, k' \leq k + 2f(c, k)\}, \\ \max\{g(c, k') \mid k' < k\}\}$$

and then setting:

$$g(c, k) = h(c, k) + f(c, k) + 1.$$

(Again, we assume  $g(1, k)$  and  $g(2, k)$  have been shown to exist for each value of  $k$ ).

We want to show that for each pair  $c$  and  $k$  of integers if  $(G, X, \Sigma)$  is an instance of  $c$ -embedded  $k$ -realizations and  $v$  is a  $g(c, k)$ -isolated vertex then any partition of  $X$  realizable in  $G$  is also realizable in  $G - v$ . We assume the contrary to derive a contradiction and choose the lexicographically smallest pair  $(c, k)$  for which this statement does not hold. So, we consider an instance  $(G, X, \Sigma)$  of  $c$ -embedded  $k$ -realizations and a  $g(c, k)$ -isolated vertex  $v$  in  $G$  such that some partition  $\Delta$  of  $X$  is realizable in  $G$  but not in  $G - v$ .

Clearly,  $\Delta$  is realizable in  $\Sigma$  for it is realizable in  $G$ . Thus one of (i)-(iii) in Theorem 5 must fail to hold for  $G - v$ .

Suppose first that there is some I-arc  $J$  with its endpoints on different cuffs which has length at most  $f(c, k)$ . Now, as in our reduction algorithm, we can cut along  $J$ , replacing each vertex  $v$  on  $J$  by two new vertices  $v_1$  and  $v_2$  to obtain from  $G$  a new graph  $G'$  embedded in a punctured plane  $\Sigma'$  with  $c - 1$  cuffs. We let  $X' = X - J + \{x_1 \mid x \in J \cap V\} + \{x_2 \mid x \in J \cap V\}$  and  $k' = |X'| \leq k + 2f(c, k)$ . We note that since  $J$  has both its endpoints in  $bd(\Sigma)$  and has length at most  $f(c, k)$  we know that it does not intersect  $D_{g(c, k) - f(c, k)}$  and hence  $v$  is  $(g(c, k) - f(c, k))$ -isolated in  $G'$ . Since  $g(c - 1, k') \leq h(c, k) < g(c, k) - f(c, k)$  we know by the induction hypothesis that any partition of  $X'$  realizable in  $G'$  is also realizable in  $G' - v$ . Now, we know that our partition  $\Delta$  was realizable in

$G$  thus there is a partition  $\Delta'$  of  $X'$  realizable in  $G'$  which yields a realization of  $\Delta$  in  $G$ . We have just remarked that  $\Delta'$  is also realizable in  $G' - v$  and thus  $\Delta$  is realizable in  $G - v$ , a contradiction.

Similar reductions apply given any short schism, or short O-arc or short I-arc with both its endpoints on the same cuff. In these cases,  $\Sigma$  may be cut into two or three pieces and we must apply induction to the piece containing  $v$ . Furthermore, if we cut through an O-arc (or a looping I-arc  $J$  such that for some component  $U$  of  $\Sigma - J$ ,  $U + J$  bounds a disc) then we may apply induction on  $k$  and not  $c$ . The tedious but routine details are left to the reader.  $\square$

We remark that essentially the same proof yields an analagous result for graphs embedded on arbitrary surfaces.

Now, the strengthening of Lemma 1 proved by Robertson and Seymour is:

**THEOREM 6.** *For every  $k$  there is a  $g(k)$  such that the following holds. Suppose  $G$  is a graph,  $H$  is a planar subgraph of  $G - X$ , there are vertex disjoint cycles  $C_1, \dots, C_{g(k)}$  in  $H$  bounding (in some embedding of  $H$ ) discs  $D_1 \subset D_2 \dots \subset D_{g(k)}$  such that no vertex of  $G - H$  is adjacent to any vertex in the interior of  $D_{g(k)}$  and  $v$  is a vertex inside  $D_1$ . Then, any partition of  $X$  realizable in  $G$  is also realizable in  $G - v$ .*

To prove this theorem, they first prove Theorem 5 and then spend six hundred pages developing structure theory which essentially says that a minimal counter-example to Theorem 6 must look more or less like a graph on a surface whose genus is bounded by a function of  $k$ . This then allows them to prove Theorem 6 using Theorem 5. It would be of great interest to obtain a direct proof of Theorem 6.

**ACKNOWLEDGEMENT.** I thank Bert Gerards for extensive editing on this paper. This included sketching the lines along which the current version runs and drawing the figures.

#### REFERENCES

1. J.A. BONDY and U.S. R. MURTY (1976). *Graph theory and applications*, Elsevier.
2. R. KARP (1975). On the computational complexity of combinatorial problems, *Networks* **5**, pp. 45-68.
3. J.F. LYNCH (1975). The equivalence of theorem proving and the interconnection problem, *ACM SIGMA Newsletter* **5.3**, pp. 31-65.
4. B.A. REED, N. ROBERTSON, A. SCHRIJVER and P.D. SEYMOUR. *Finding Disjoint Trees on a Surface*, unpublished.
5. B.A. REED, N. ROBERTSON, A. SCHRIJVER and P.D. SEYMOUR (1993). Finding Disjoint Trees in Planar Graphs in Linear Time, *Contemporary Mathematics* **147**, pp. 295-301.
6. N. ROBERTSON and P.D. SEYMOUR (1986). Graph minors. II. Algorithmic aspects of tree-width, *J. Algorithms* **7**, pp. 309-322.

7. N. ROBERTSON and P.D. SEYMOUR (1986). Graph minors VI. Disjoint paths across a disk, *J. Combin. Theory Ser. B* **41**, pp. 115-138.
8. N. ROBERTSON and P.D. SEYMOUR (1988). Graph minors VII, Disjoint paths on a surface, *J. Combin. Theory Ser. B* **45**, pp. 212-254.
9. N. ROBERTSON and P.D. SEYMOUR (1986). *Graph minors XIII, The disjoint path problem*, preprint.
10. P.D. SEYMOUR (1980). Disjoint paths in Graphs, *Discrete Mathematics* **29**, pp. 293-309.
11. Y. SHILOACH (1980). A polynomial solution to the undirected two paths problem, *J. Assoc. Comp. Mach.* **27**, pp. 445-456.
12. H. SUZUKI, T. AKAMA and T. NISHISEKI (1989). An algorithm for finding a forest in a planar graph - case in which a net may have terminals on two specified face boundaries, *Electronics and Communications in Japan, Part III: Fundamental Electronic Science* **72**, pp. 10:68-79.
13. C. THOMASSEN (1980). 2-linked graphs, *European Journal of Combinatorics* **1**, pp. 371-378.
14. A.T. WHITE (1984). *Graphs, groups and surfaces*, Elsevier.